



FACE DRILL RIG WD561

Mining one-boom face drill rig for small sized underground drifts, with minimum coverage area 4m²

With quality as the foundation and innovation as the driving force, Uniroc creates greater value for you.

 unirocgroup.com
 tunnel@unirocgroup.com



Youtube



Facebook

Reliable and Durable Rig

Main features:

1# Compact structure & high efficiency:

Small dimensions, minimum 1.9m×1.9m working section. Fast drilling speed, equipped with 18kW rock drill, up to 2.5m/min.

2# Easy:

Adopting electro-proportional hydraulic control makes drilling and positioning more convenient, flexible and precise.

3# Automatic:

With automatic drilling, automatic retraction, automatic jamming release, automatic stopping impact and other functions.

4# Digital:

Digitally record the number of holes drilled, drilling depth and other data, real-time supervision and evaluation of the construction situation.

5# Safety:

Equipped with self-diagnosis and safety voice alarm system, real-time monitoring and fault detection.

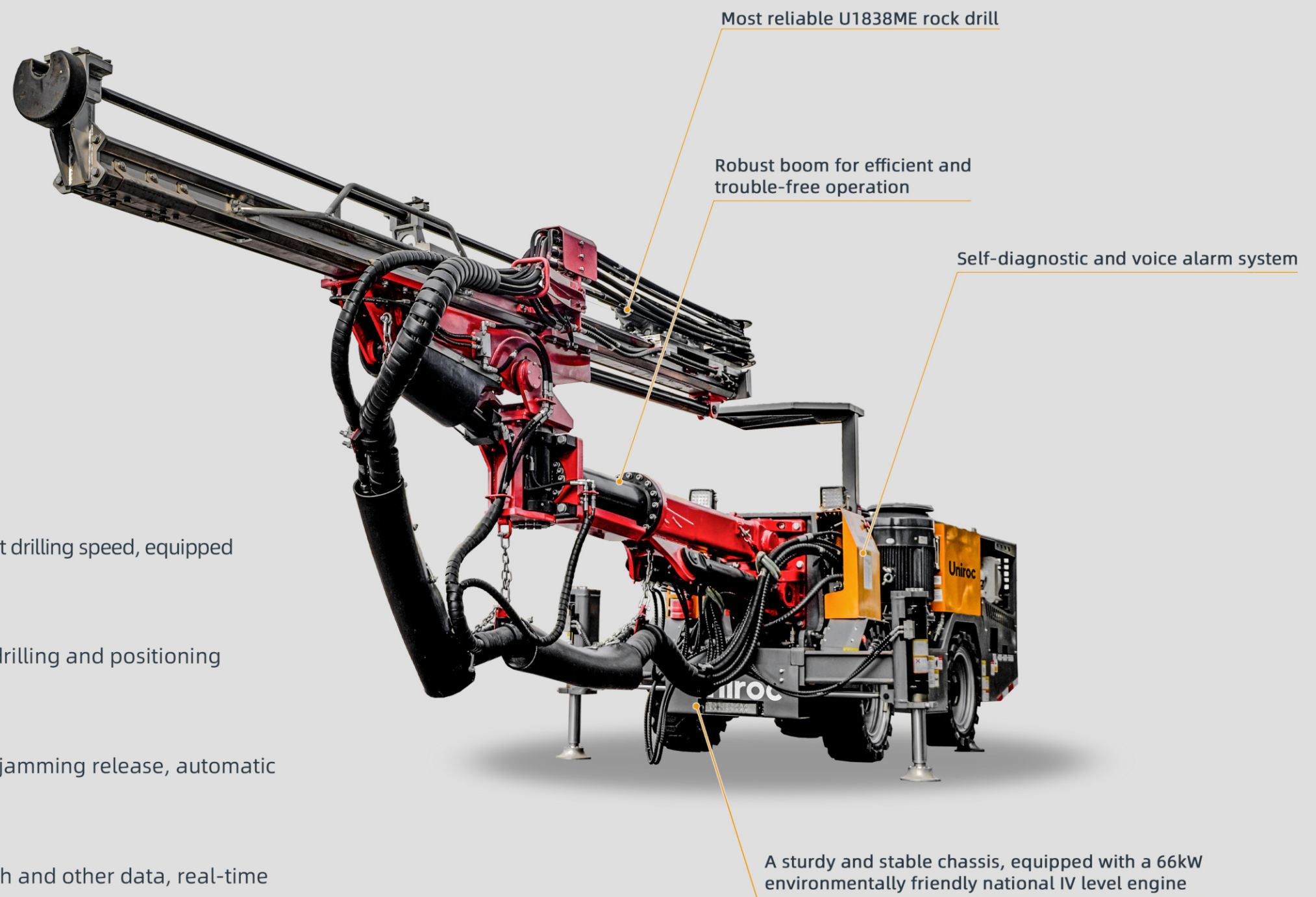

Face Drill Rig WD561

A Partner Worthy Of Your Trust

Uniroc U1838ME Rock Drill



Our self-developed rock drill U1838ME is specially equipped with a secondary buffer system, which greatly extends the service life of the hydraulic rock drill. It is also equipped with advanced frequency conversion system at all levels, which enables it to flexibly cope with a wide range of different levels of surrounding rock conditions, completely solving the limitation of traditional rock drills that are difficult to be used for multiple purposes.

Remote control operation



Remote control electric proportional hydraulic intelligent control system, no blind spots in the field of vision during operation, personnel stay away from dangerous places, safe and reliable; Visual adjustment of operation parameters, which can be pre designed to flexibly respond to different working conditions.

Drilling System



Adopting high efficient and fast electro-proportional hydraulic control drilling system, including automatic drilling, automatic retraction, automatic release of jamming brazier and other functions.

Professional service offering



Uniroc's service solutions ensure that your equipment performs at its best throughout its life cycle.

By combining genuine parts and Uniroc services from our certified technicians, we provide the highest quality technical support to ensure that your equipment continues to run efficiently and safely.

Measurements

Side View

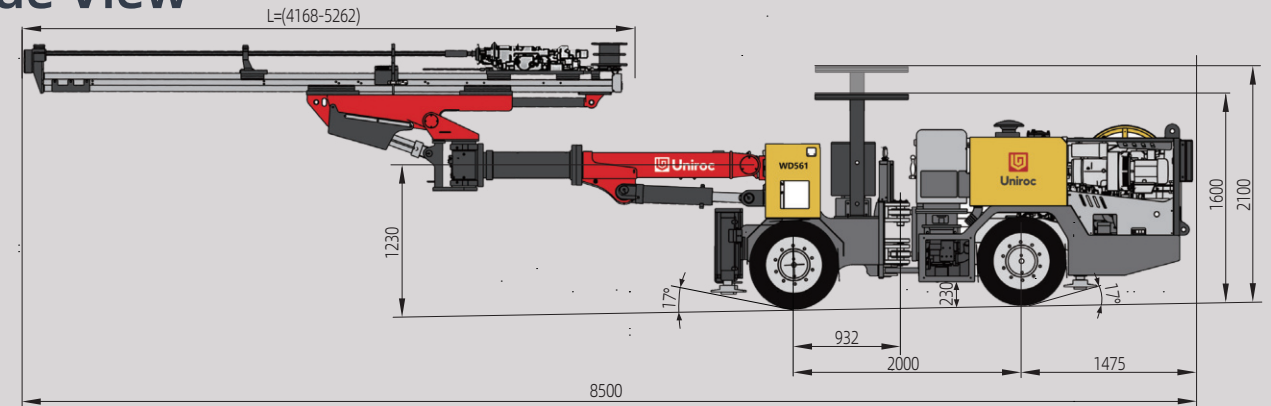

Coverage Area

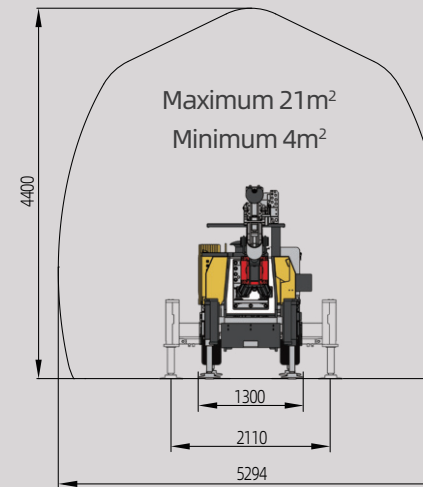

Turning Radius

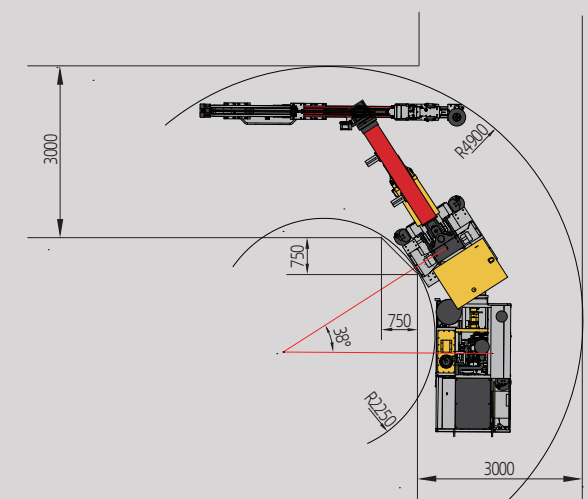

Dimensions		
mm	Width	1300
	Height roof up/down	1600/2100
	Length with BMH A feed	8500
	Ground clearance	230
Weight		
Gross weight, depending on configuration		
kg	Total	8500
	Boom side	2700
	Engine side	5800
Tramming speed		
km/h	On flat ground(rolling resistance 0.05)	>4

Face Drill Rig WD561

Technical Specifications

Rock drill	
Shank adapter	T38
Height over drill centre	88mm
Length without shank	1008mm
Impact power	18kW
Impact rate	60Hz
Rotation system	Separate rotation
Rotation speed, max	215rpm
Rotation torque, max	1000Nm
Lub.air consump.at 2 bar	5L/s
Water consumption	40-120L/min
Sound level	<128dB(A)

Carrier	
Power rating at 2200 rpm	66kW (90 hp)
Torque at 2200 rpm	360Nm
Articulated steering	38° steering angle
Rear axle	±7° oscillation
Tyres	31×10-20
Hydraulic jacks, front	2 extendable
Hydraulic jacks, rear	2
Service brakes	2 separate circuits
Emergency and parking brakes	Spring brake
Fuel tank, volume	50L
Electric system	24V
Batteries	2×12V, 120Ah
Driving lights	LED 1×72W & 2×30W 24V DC
Working lights	LED 2×100W, 24V DC
Gradeability at max load on drive wheels	15°
Water-cooled diesel engine, Chinese Stage IV	
Fixed seat for tramming	
Four-wheel drive	
Hydrostatic transmission	
Silencer	
Fire extinguisher	
Spirit level	
Horn, beacon and reverse alarm	

Control system	
Remote electro-proportional hydraulic control system	
Basic functions such as anti-jamming included	

Electrical system	
Total installed power	65kW
Main motor	1×55kW
Voltage	380V/660V
Frequency	50Hz
Starting method	star/delta
Transformer	0.3kVA(660V/6kVA)
Cables reel	530/871mm
Thermal overload protection for electric motors	
Percussion hour meters	
Digital voltmeter/ampere meter in display	
Phase sequence indicator	
Battery charger	

Boom	
Feed extension	1500 mm
Feed roll-over	360°
Lifting angle	+42°/-28°
Boom swing angle L/R	±35°
Weight, Boom only	1250 kg

Hydraulic system	
Hydraulic pumps	1 unit
System pressure, max	230bar
Hydraulic oil tank, volume max	135L
Filtration	10um
Oil filter indicator	
Low oil level indicator	
Water cooled oil	
Mineral hydraulic oil	

Air system	
Capacity max. at 7 bar	6.8 L/s
Air pressure gauge	

Water system	
Water booster pump working capacity, L/min	25-80
Water booster pump working pressure, bar	8-12
Min. water inlet pressure, bar	2
Water flow guard	

Feed			
	Model A Standard	Model B Optional	Model C Optional
Total length	5262mm	4658mm	4168mm
Drill rod length	3700mm	3090mm	2600mm
Hole depth	3400mm	2800mm	2300mm
Weight, incl. drill	610kg	570kg	540kg
Feed force	7-15kN	7-15kN	7-15kN

Optional equipment

Drifter rods		
Dimension		Min. hole diameter
mm	R32-H35-R38	45
	R32-H35-T38	45
	R32-H35-T38 Speedrod	45
	R32-D39-T38	45
	R32-D39-T38 Speedrod	45

Shank			
mm	Shank type	Length of shank	Diameter of shank
	R32	435	38
	R32	525	38
	R32	435	38
	HM38	525	38
	T38	435	38

Couplings			
Thread		Diameter	Length
mm	R38	55	170
	T38	58	190

Rock drill	
Big hole drilling kit	

Feed	
Telescopic feed	

Face Drill Rig WD561